



CAPACITIVE PRESSURE TRANSMITTER

FROM 1 mbar FULL RANGE* / RESOLUTION 1 μ bar

The Series 41 X combines the ceramic measurement cell for low pressure ranges with the μ P electronics of the digital Series 30 transmitter. The pressure values from the signals of the pressure and temperature sensors are determined by polynomial compensation (see reverse). The values can be displayed and stored on a PC via an RS485 interface and programming can also be carried out.

The transmitters are calibrated to the base range. The PROG30 software permits programming of the analog output signal in each section of the range within the base range (e.g. range 100 mbar. Output 4...20 mA for 20...60 mbar).

With KELLER RS converters K-100 Series, up to 128 transmitters can be hooked together into a bus system and read by means of a PC or laptop. READ30 software allows the current pressure of each transmitter to be read or the pressure activity of several transmitters to be recorded or stored whilst "on line".

This pressure transmitter is also available as intrinsically safe version (Series 41 X Ei). It is used in explosion exposed areas, where the categories 1 and 2 are required.



*by splitting the 10 mbar range

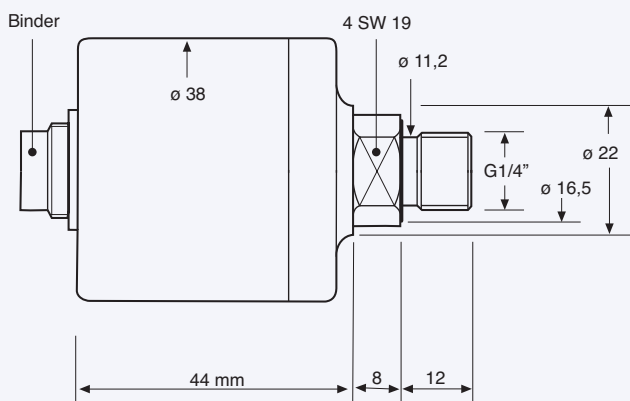

ELECTRICAL CONNECTIONS

Output	Function	Binder 723	DIN 43650	MIL C-264882	Lumberg M12	Cable
4...20 mA	OUT/GND	1	1	C	1	white
2 Wire	+Vcc	3	3	A	3	black
0...10 V	GND	1	1	C	1	white
3 Wire	+OUT	2	2	B	2	red
	+Vcc	3	3	A	3	black
Digital	RS485A	4		D	4	blue
	RS485B	5		F	5	yellow





Specifications

	Standard FS Pressure Ranges		
PR-41 X (relative) PD-41 X (diff.)	30	100	300 mbar
Overpressure	300	1000	1500 mbar
Neg. Overpressure	30	100	300 mbar
	2-Wire	3-Wire	
Supply (U _B) 41 X	8...28 VDC	13...28 VDC	
Supply (U _B) 41 X Ei	10...30 VDC	15...30 VDC	
Analog Output (scaleable)	4...20 mA	0...10 V	
Load (kΩ)	<(U _B -U _{Bmin}) / 20 mA	≥ 100	
Error Band typ.*	± 0,1 %FS	± 0,2 %FS	
Error Band max.*	± 0,2 %FS	± 0,3 %FS	

* Within the compensated temperature range

Stability	FS ≥ 100 mbar: ± 0,1 %FS	FS ≤ 100 mbar: ± 0,1 mbar
Operating Temperature	-20...80 °C	
Compensated Range	10...50 °C	

Pressure Connection	G1/4" male, Viton® flat seal
Electrical Connection	Binder Series 723 (5 pole)
Material in Contact with Media	Stainless steel (AISI 316L), Nitril O-ring, gold-coated ceramic diaphragm
PD-Reference side	Non-aggressive dry gases
Protection / Weight	IP 40 / ca. 190 g
Special Versions	- IP 67 - Alternative plugs (see front page) - Cable version - Pressure ranges neg./pos.: Example: -10...+10 mbar - Intrinsically safe version for use in explosion exposed areas (must only be used in combination with certified intrinsically safe equipment!)

All intermediate ranges for the analog output are realizable with no surcharge by spreading the standard ranges. ** Option: Adjustment directly to intermediate ranges (below 20 pieces against surcharge). For higher pressure ranges and for "wet/wet"-differential applications, KELLER offers Series 33 X resp. Series 39 X.

** Note that the error band will then increase proportionally



PD-41 X
Dimensions ø 50 x 62 mm

Polynomial Compensation

This uses a mathematical model to derive the precise pressure value (P) from the signals measured by the pressure sensor (S) and the temperature sensor (T). The microprocessor in the transmitter calculates P using the following polynomial:

$$P(S,T) = A(T)S^0 + B(T)S^1 + C(T)S^2 + D(T)S^3$$

With the following coefficients A(T)...D(T) depending on the temperature:

$$A(T) = A_0 \cdot T^0 + A_1 \cdot T^1 + A_2 \cdot T^2 + A_3 \cdot T^3$$

$$B(T) = B_0 \cdot T^0 + B_1 \cdot T^1 + B_2 \cdot T^2 + B_3 \cdot T^3$$

$$C(T) = C_0 \cdot T^0 + C_1 \cdot T^1 + C_2 \cdot T^2 + C_3 \cdot T^3$$

$$D(T) = D_0 \cdot T^0 + D_1 \cdot T^1 + D_2 \cdot T^2 + D_3 \cdot T^3$$

The transmitter is factory-tested at various levels of pressure and temperature. The corresponding measured values of S, together with the exact pressure and temperature values, allow the coefficients A0...D3 to be calculated. These are written into the EEPROM of the microprocessor.

When the pressure transmitter is in service, the microprocessor measures the signals (S) and (T), calculates the coefficients according to the temperature and produces the exact pressure value by solving the P(S,T) equation.

Accessories Series 41 X

Each Series 41 X transmitter also integrates a digital interface (RS485 halfduplex) which the user can make use of. The transmitter is being connected via a converter RS232-RS485 (i.e. K-102, K-104 or K-107) to a PC or Laptop. Two programs are offered:

PROG30: Instrument Settings

- Call up of information (pressure- and temperature range, version of software etc.)
- Indication of actual pressure value
- Selection of the units
- Setting of a new zero and gain for the transmitter
- Reprogramming of the analog output (i.e. different unit, other pressure range)
- Setting of the instrument address (for Bus-operation)
- Programming of the switch output
- Changing the output rate

READ30: Data collection with graphs

- Fast read-out and viewing of the pressure signals in a graph
- Documentation of dynamic measurements
- Up to 16 transmitters on one serial connection (Bus-operation)

Software PROG30

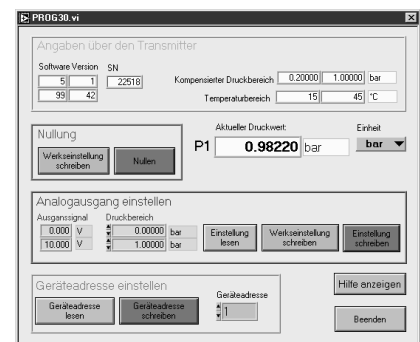

You can also tie up the transmitters into your own software. You have then a documentation, a DLL and numerous examples at your disposal.