



# HIGHLY PRECISE (0,01%) PRESSURE TRANSMITTERS

MATHEMATICALLY COMPENSATED / PROGRAMMABLE

## SERIES 33 X SERIES 35 X

### Digital Output of Transmitter

This high precision of 0,01 %FS is available as an option (the standard Series 33 X has an accuracy of 0,05 %FS). These Series are based on the stable, floating piezoresistive transducer and the newly developed XEMICS micro-processor with integrated 16 bit A/D converter. Temperature dependencies and non-linearities of the sensor are mathematically compensated. With the READ30 software and the KELLER cable K-107, the calculated pressure can be displayed on a Laptop or PC. The READ 30 software also allows the recording of pressure signals and the graphic display on the PC. Up to 128 transmitters can be hooked together to a Bus-system.

### Transmitter with Analog Output

Integrated in the XEMICS processor is a D/A converter of 16 bit for analog signal outputs of 4...20 mA or 0...10 V. The output rate is 400 Hz. The accuracy is diminished by this converting process by 0,05 %FS. The digital output is available on all transmitters with analog output.

### Programming

With the KELLER software READ30 and PROG 30, a RS485 converter (i.e. K102 or K107 from KELLER) and a PC, the pressure can be displayed, the units changed, a new gain or zero set. The analog output can be set to any range within the compensated range.

### Accuracy and Precision

"Accuracy" is an absolute term, "Precision" a relative term. Dead weight testers are primary standards for pressure, where the pressure is defined by the primary values of mass, length and time. Highest class primary standards in national laboratories indicate the uncertainty of their pressure references with 70 to 90 ppM or close to 0,01%.

Commercial dead weight testers as used in our facilities to calibrate the transmitters indicate an uncertainty or accuracy of 0,025%. Below these levels, KELLER use the expression "Precision" as the ability of a pressure transmitter to be at each pressure point within 0.01 %FS relative to these commercial standards.

The transmitter's full-scale output can be set up to match any standard of your choice by correcting the gain with the PROG30 software.



Series 33 X  
G1/4" thread



Series PD-33 X



Series 35 X  
G1/2", flush diaphragm

**PIN ASSIGNMENT**

Output	Function	MIL C-26482	Binder 723	DIN 43650
4...20 mA	OUT/GND	C	1	1
2 Wire	+Vcc	A	3	3
0...10 V	GND	C	1	1
3 Wire	OUT	B	2	2
	+Vcc	A	3	3
Digital	RS485A	D	4	
	RS485B	F	5	

Serie 33 X (G1/4")
Serie PD-33 X with DIN 43650 Connector
Serie 35 X (G1/2")



## Specifications

	Standard Pressure Ranges (FS) and Overpressure in bar							
PR 33 X / PD 33 X / PR 35 X	1	3	10	30				
PA(A) 33 X / PA(A) 35 X	0,8...1,2	1	3	10	30	100	300	700 1000
Overpressure	2	2	5	20	60	200	400	1000 1000
Overpr. referential pressure side PD	2	5	7	20				
PD, static line pressure* standard / high Pressure	200 bar / 600 bar							

All intermediate ranges for the analog output are realizable with no surcharge by spreading the standard ranges.  
Option: Adjustment directly to intermediate ranges (below 20 pieces against surcharge).

PAA: Absolute. Zero at vacuum  
PA: Sealed Gauge. Zero at atmospheric pressure (at calibration day)  
PR: Vented Gauge. Zero at atm. pressure  
PD: Differential

	(digital)	(analog, 2-wire)	(analog, 3-wire)		
Output	<b>RS 485</b>	<b>4...20 mA</b>	<b>0...10 V</b>	<b>0...2,5 V / 0...5 V</b>	<b>0,1...2,5 V</b>
Supply (U)	8...28 V / 3,5...12 V	8...28 V	13...28 V	6...28 V / 8...28 V	3,5...12 V
Accuracy, Error Band (10...40 °C)	0,05 %FS	0,1 %FS	0,1 %FS	0,1 %FS	0,1 %FS
Accuracy, Error Band (-10...80 °C)	0,1 %FS	0,15 %FS	0,15 %FS	0,15 %FS	0,15 %FS
<b>Optional: Precision**</b> (10...40 °C)	<b>0,01 %FS</b>				

\* Influence static line pressure < 0,005 %FS/bar  
\*\* Only for Series PA(A) 33 X and for ranges ≥ 10 bar

True Output Rate	400 Hz
Resolution	0,002 %FS
Long Term Stability typ.	Gauges: 1 mbar or 0,05 %FS Absolute: 0,5 mbar or 0,025 %FS (10...40 °C)
Load Resistance (Ω)	<(U - 8 V) / 0,025 A (2-wire) > 5'000 (3-wire)
Electrical Connection	- MIL C-26482-Plug (6 pole) - Binder-Plug 723 (5 pole) - DIN 43650 Plug (4 pole)
Insulation	10 MΩ / 50 V, optional 300 V (2-wire only)
Storage-/Operating Temperature Range	-40...120 °C
Pressure Endurance	10 Million Pressure Cycles 0...100 %FS @ 25 °C
Vibration Endurance	20 g (5...2000 Hz, max. amplitude ± 3 mm), according to IEC 68-2-6
Shock Endurance	20 g (11 ms)
Protection	IP 65 optional: IP 67 or IP 68 (with cable)
CE-Conformity	EN 61000-6-1 to -6-4 / EN 61326-2-3
Material in Contact with Media	Stainless Steel AISI 316L / Viton
Weight	Series 33 X ≈ 240 g; Series 35 X ≈ 180 g; Series PD-33 X ≈ 500 g
Dead Volume Change	< 0,1 mm <sup>3</sup>

### Polynomial Compensation

This uses a mathematical model to derive the precise pressure value (P) from the signals measured by the pressure sensor (S) and the temperature sensor (T). The microprocessor in the transmitter calculates P using the following polynomial:

$$P(S,T) = A(T) \cdot S^0 + B(T) \cdot S^1 + C(T) \cdot S^2 + D(T) \cdot S^3$$

With the following coefficients A(T)...D(T) depending on the temperature:

$$A(T) = A_0 \cdot T^0 + A_1 \cdot T^1 + A_2 \cdot T^2 + A_3 \cdot T^3$$

$$B(T) = B_0 \cdot T^0 + B_1 \cdot T^1 + B_2 \cdot T^2 + B_3 \cdot T^3$$

$$C(T) = C_0 \cdot T^0 + C_1 \cdot T^1 + C_2 \cdot T^2 + C_3 \cdot T^3$$

$$D(T) = D_0 \cdot T^0 + D_1 \cdot T^1 + D_2 \cdot T^2 + D_3 \cdot T^3$$

The transmitter is factory-tested at various levels of pressure and temperature. The corresponding measured values of S, together with the exact pressure and temperature values, allow the coefficients A<sub>0</sub>...D<sub>3</sub> to be calculated. These are written into the EEPROM of the microprocessor.

When the pressure transmitter is in service, the microprocessor measures the signals (S) and (T), calculates the coefficients according to the temperature and produces the exact pressure value by solving the P(S,T) equation.

Calculations and conversions are performed at least 400 times per second.

### Remarks:

- Disturbance of the 4...20 mA signal can occur during communication through RS485
- All versions are also available for use in hazardous areas (Ei-versions); see sep. data sheet
- Options:
  - Calculations such as density, differential pressure, flow, absolute value, etc.
  - Different housing-material, oil filling, pressure thread or connector

### Accessories Series 30

Each Series 30 transmitter also integrates a digital interface (RS485 halfduplex) which you can make use of: Connect the transmitter to a PC or Laptop via a converter RS232-RS485 (i.e. K102 or K107) or USB-RS485 (K104 or K104B). Two programs are offered for free:

#### PROG30: Instrument Settings

- Call up of information (pressure- and temperature range, version of software etc.)
- Indication of actual pressure value
- Selection of the units
- Setting of a new zero and gain for the transmitter
- Reprogramming of the analog output (i.e. different unit, other pressure range)
- Setting of the instrument address (for Bus-operation)
- Low-Pass Filter adjusting possibility

#### READ30: Data collection with graphs

- Fast read-out and viewing of the pressure signals in a graph
- Documentation of dynamic measurements
- Up to 16 transmitters on one serial connection (Bus-operation)

#### Software PROG30

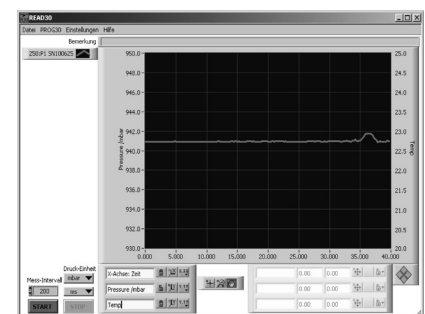

You can also tie up the transmitters into your own software. You have then a documentation, a DLL and numerous examples at your disposal.

### Changing the plug connector

Laboratory applications require the same transmitter to be used at different measurement points with different electrical connection arrangements. To accommodate such applications, KELLER can supply different connectors matching with the internal standard plug. This makes it easy to exchange the electrical connector of the transmitter.